

Air Duct

Base Mount

Table Mounting Ring

Top
Drill Table
By GME
03-10-2009
Rev 1f
Layer: 0 Top
Top Sheet
3/4" MDF
Part B-1

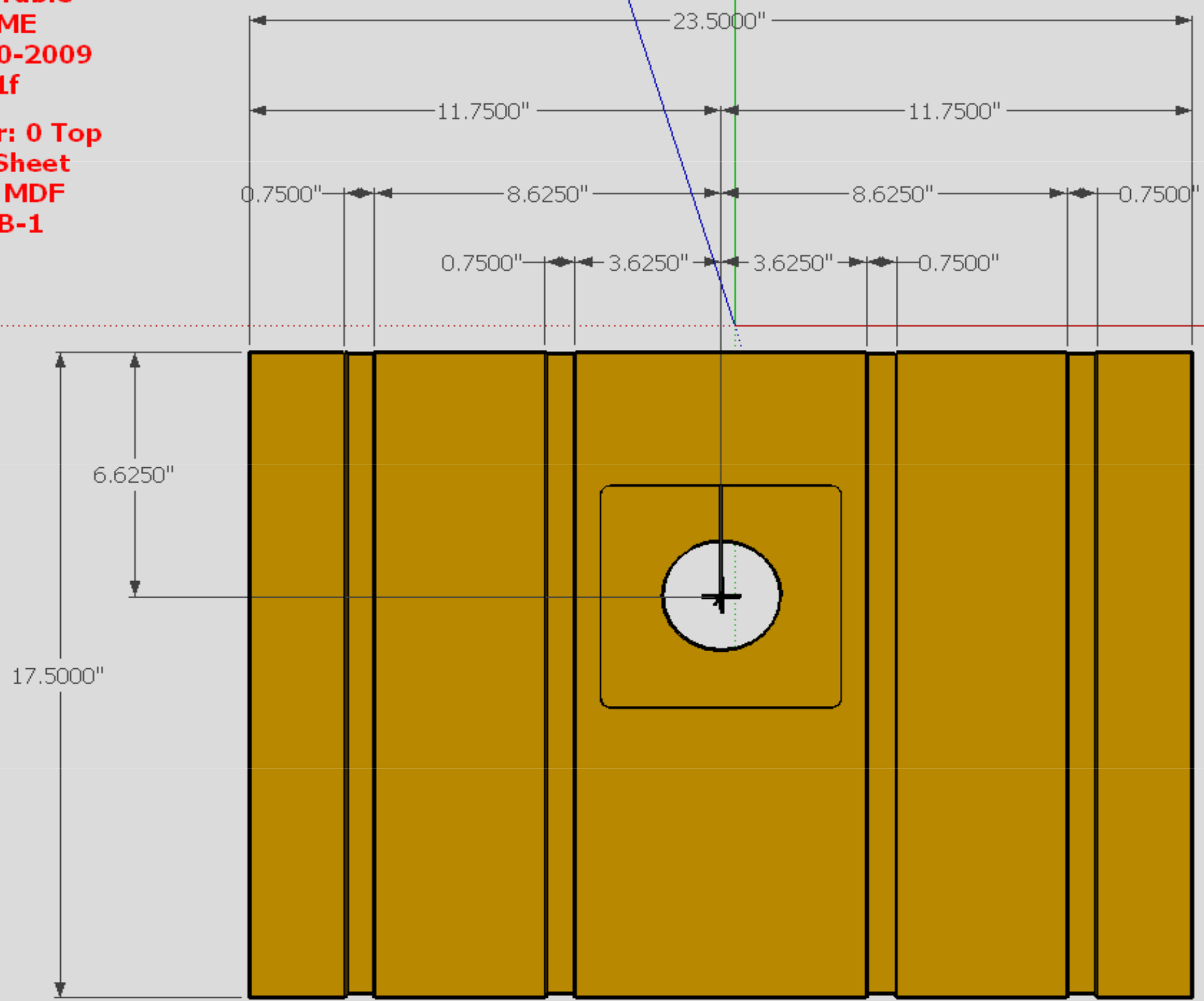

Top

Layers

Drill Table
By GME
03-10-2009
Rev 1f

Layer: 1 Top Bottom
Bottom sheet for top
glue up.
3/4" MDF
Part B-2

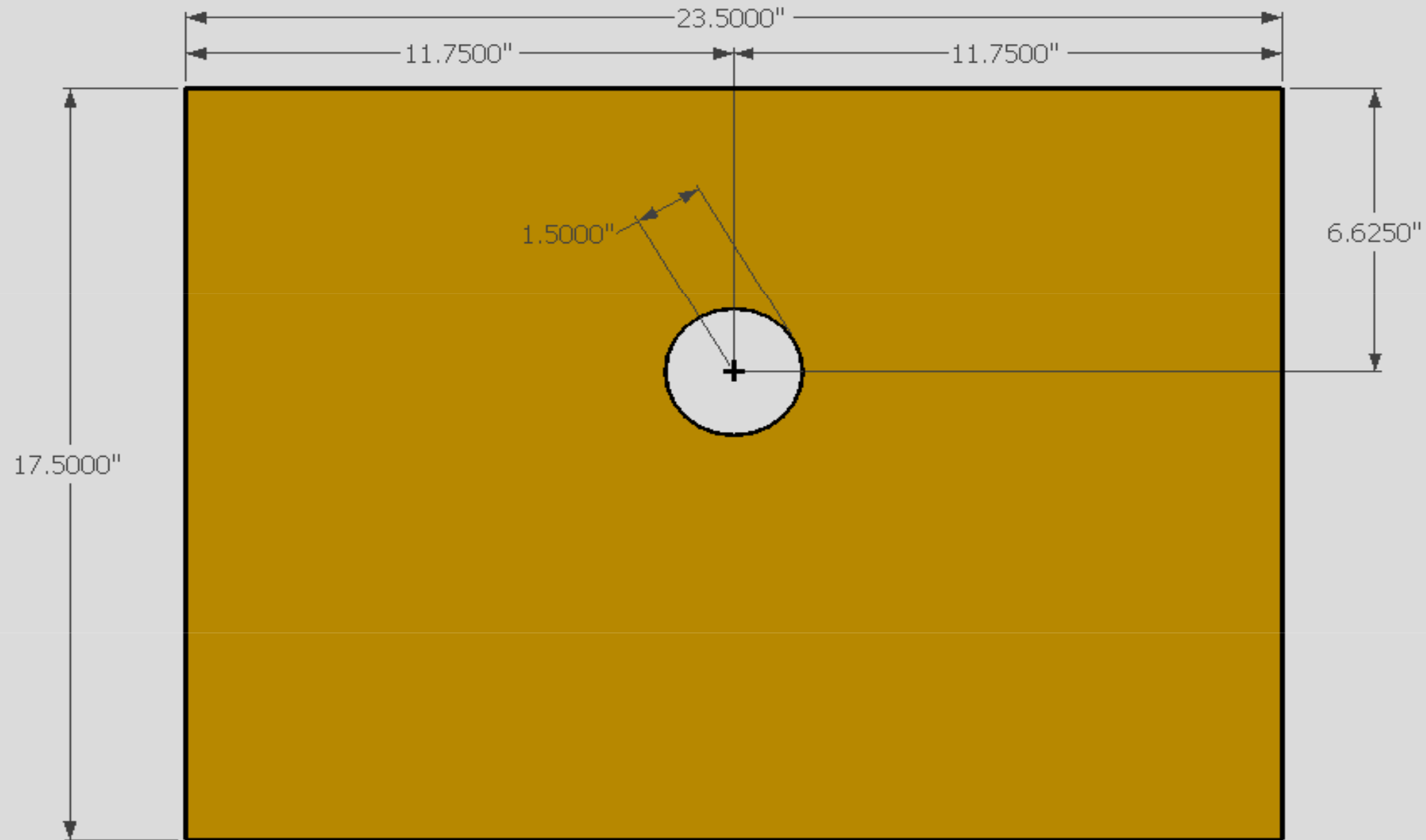

Top

Layers

Drill Table
By GME
03-10-2009
Rev 1f

Layer: 3 Air Duct
Air Duct
3/4" MDF
Part A-1

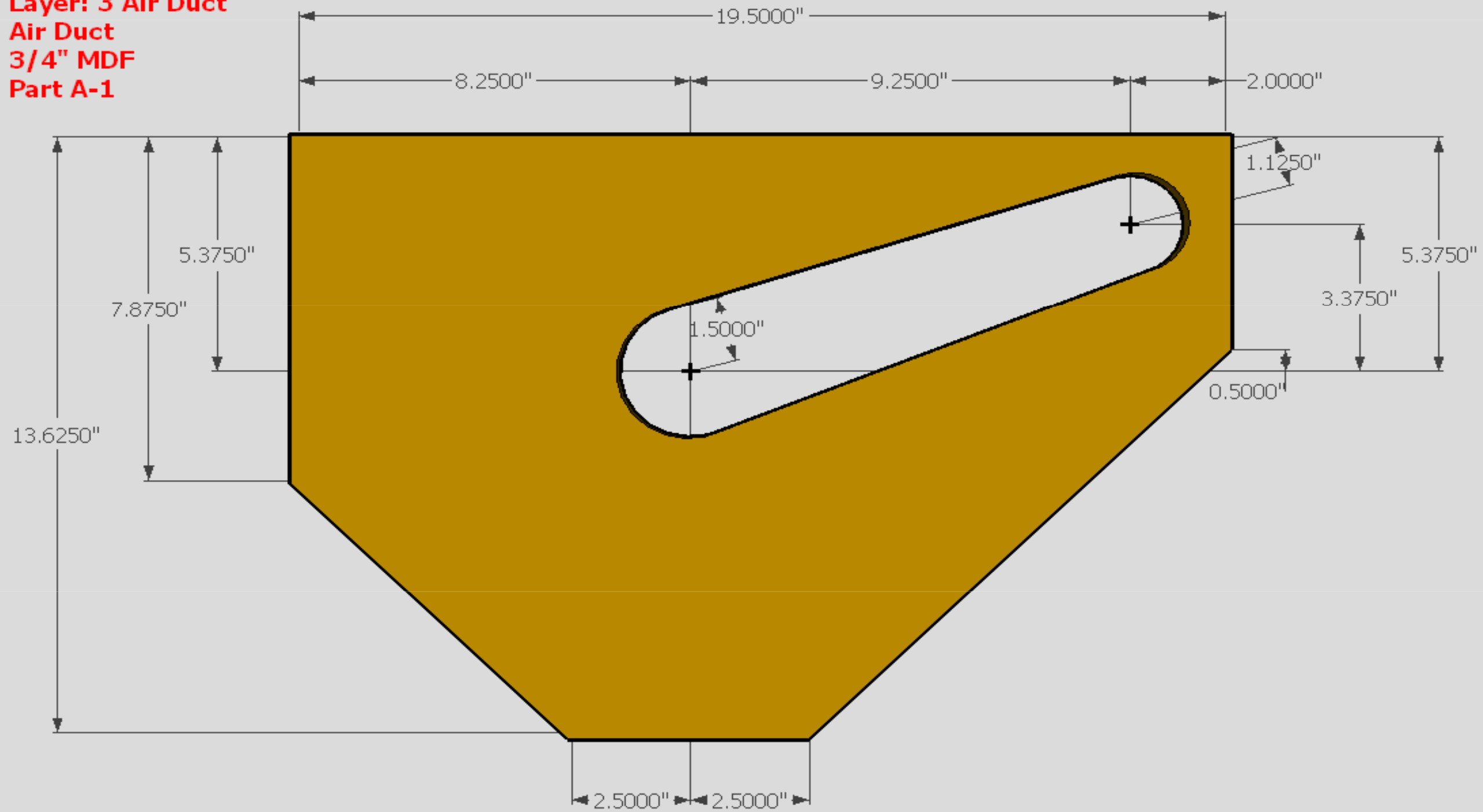

Top
Drill Table
By GME
03-10-2009
Rev 1f

Layer: 4 Base Mount
Base Mount
3/4" MDF
Part A-2

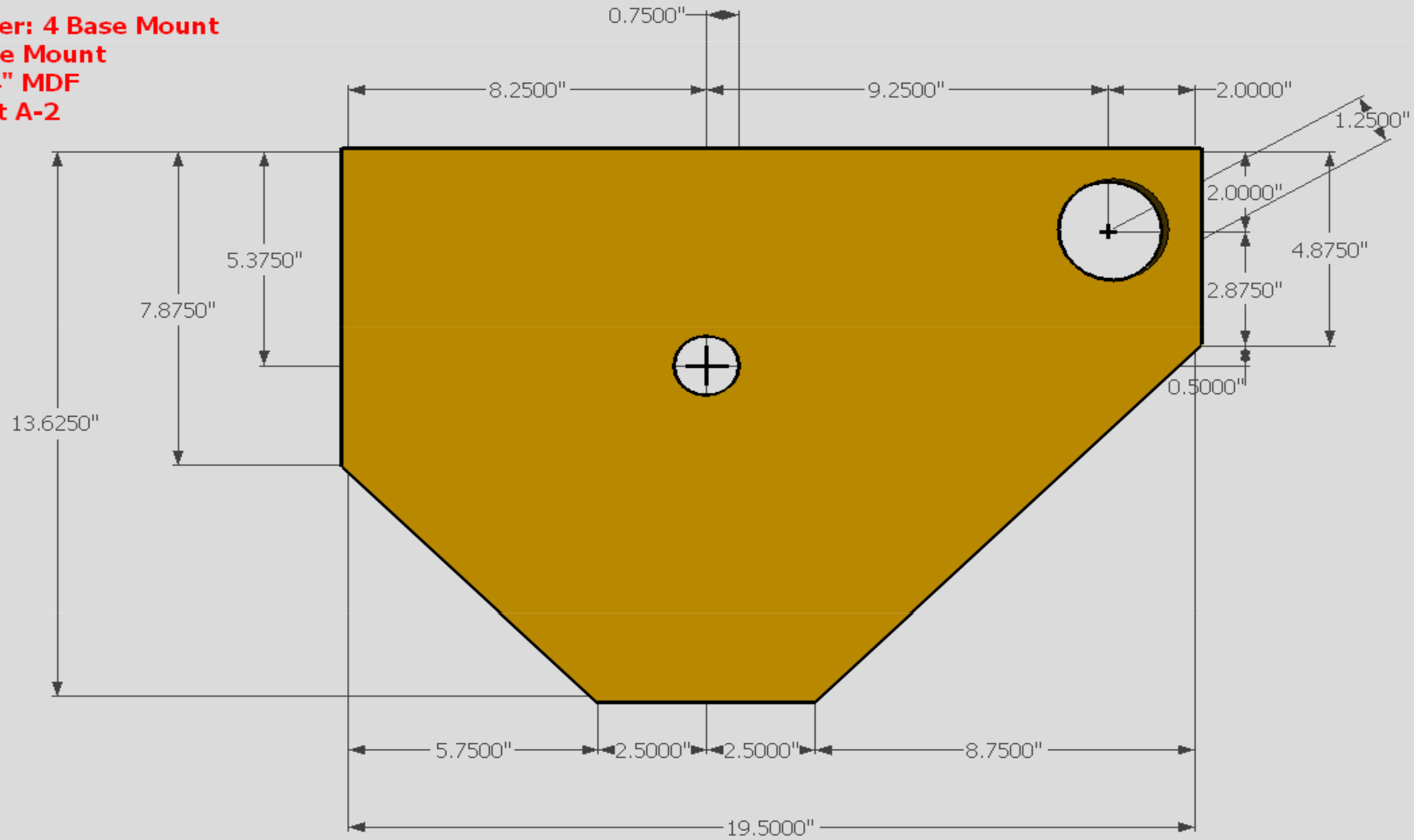

Top
Drill Table
By GME
03-10-2009
Rev 1f

Layer: 5 Table Mounting Ring
Mounting Ring
3/4" MDF
Part A-3

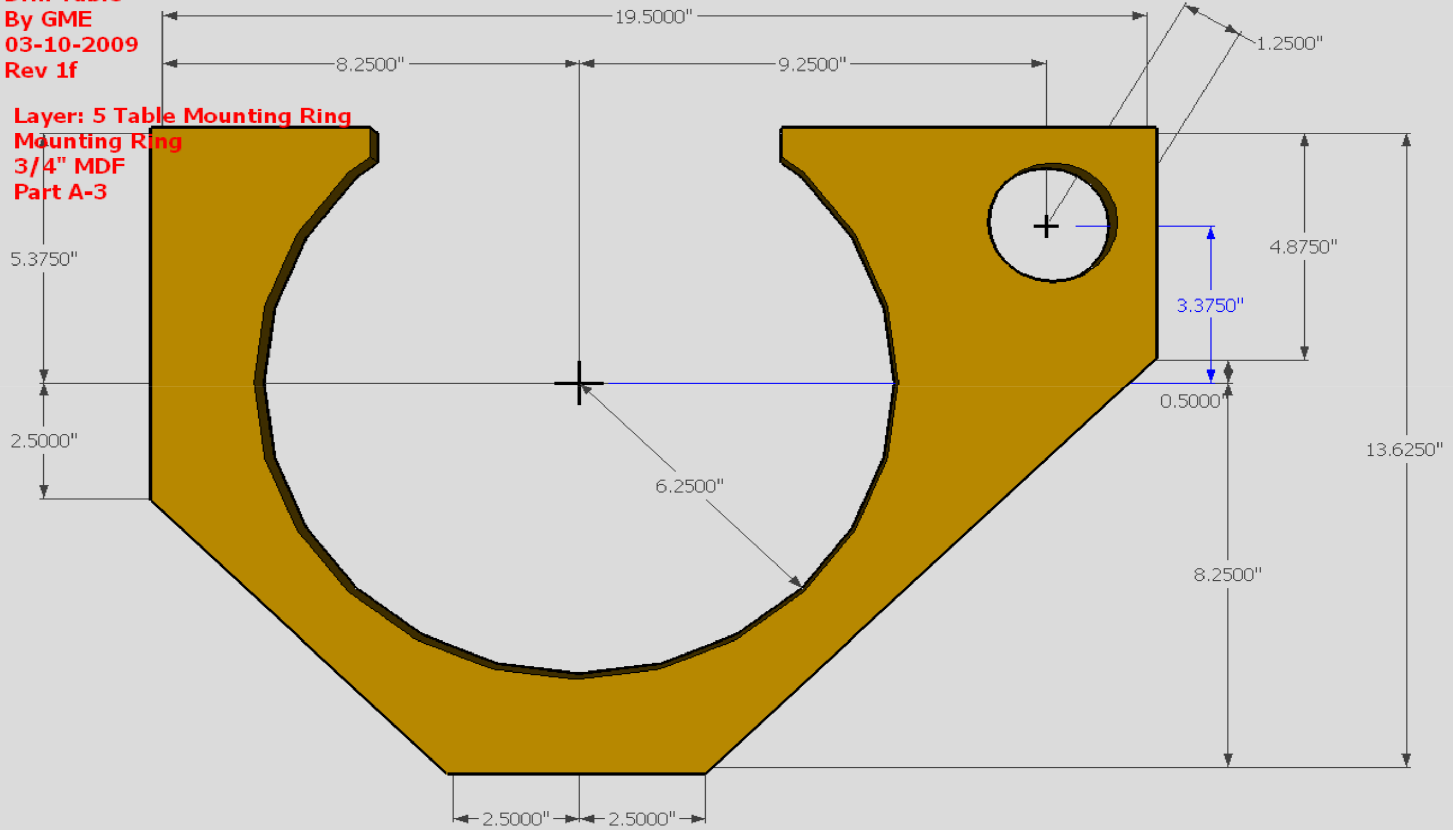

Top

Layers

Drill Table
By GME
03-10-2009
Rev 1f

Layer: 7 Fence
-
3/4" MDF
Part Fence

