



TRADITIONAL FACE VISE

All About

Bench Vises

The key to great results when working at your bench is securely holding your workpiece.

What is it that really turns a “bench” into a workbench? For a woodworker, it’s a bench vise. More specifically, a face vise and tail vise that allow you to quickly and securely clamp just about anything.

TRADITIONAL FACE VISE

Most woodworkers are familiar with a face (or front) vise. It’s the simplest to build in or bolt on to the front edge of just about any workbench.

Vise Sizes. Another reason face vises are so popular is you’ll find them in a number of different sizes. By sizing, I mean the maximum size workpiece you can clamp in the vise. The thing you need to keep in

mind is that the maximum doesn’t take into account any auxiliary wood jaws you may add to the vise. Or how it’s installed.

For example, the face vise you see above has a maximum capacity of 13". But that’s a bit misleading. In order to securely hold a workpiece, there’s a massive wood jaw at the front and a “built-in” jaw at the back — reducing the capacity to 7³/₄". Still, that’s more than enough capability for most woodworking tasks.

Build It In or Add It On. What’s nice about this vise is you can build it in to a new bench, or add it on to an existing bench. It’s easy because the vise is just an assembly of

precision-machined guide rods, a threaded shaft, and pair of heavy-duty castings, as shown above.

To complete the vise and securely hold a workpiece, you need to add a pair of wood jaws. One of the wood jaws attaches to the front of the vise. While the rear “jaw” is formed by the apron of the bench and an extended jaw.

Some larger vises feature steel collars that provide additional support for the guide rods. These collars are attached to a jaw extension below the apron of the workbench.

BOLT-ON FACE VISE

A close cousin to the traditional face vise you see above is the one shown on the opposite page.

What makes this vise different is the metal jaws cast into the vise itself. You can add this to an existing workbench and be working right away by just bolting it in place. But metal jaws can be hard on a workpiece, so it’s a good

idea to screw a couple wood jaws in place for protection.

There is one problem with bolting a vise like this in place. If you want to clamp a long workpiece along the front edge, it won't rest flush with the front of the bench. This can make it a hassle to add additional clamps for support.

Building It In. If you're building a new bench, you can solve this problem by "burying" the rear jaw into the apron of the bench (Cross Section at right). By creating a pocket in the apron *before* it's attached to the top, you end up with a built-in wood "jaw."

Quick-Release. One "upgrade" to look for in a bolt-on vise is quick-release feature. With a quick-release, you don't have to spend a lot of time rotating the handle of the vise around and around to open or close the jaws to match your workpiece. You can do it in one quick and easy motion.

The *Jorgensen* vise shown here features a half-nut that releases when you rotate the handle counterclockwise. Other manufacturers use a spring-loaded lever on the front to accomplish the same thing.

The Next Level. A face vise is just one way to make a workbench work harder. For a couple more ways, take a look at the vises on the next page.

BOLT-ON FACE VISE

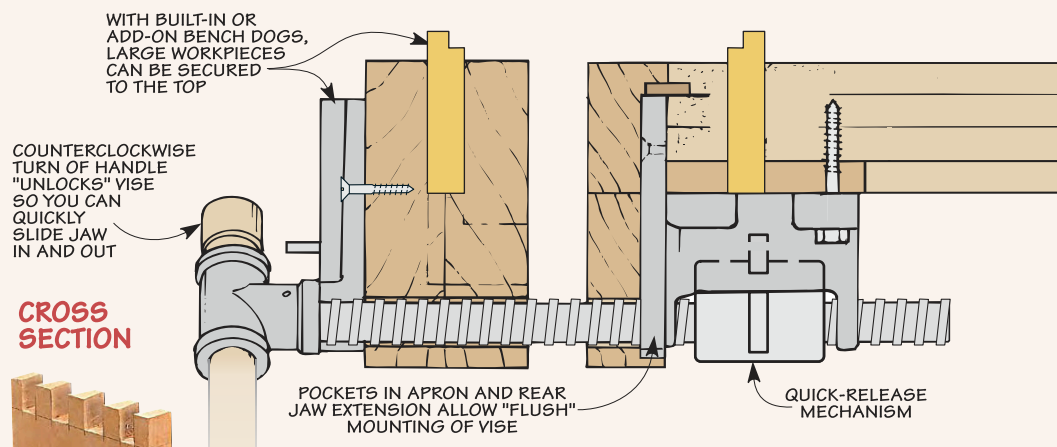
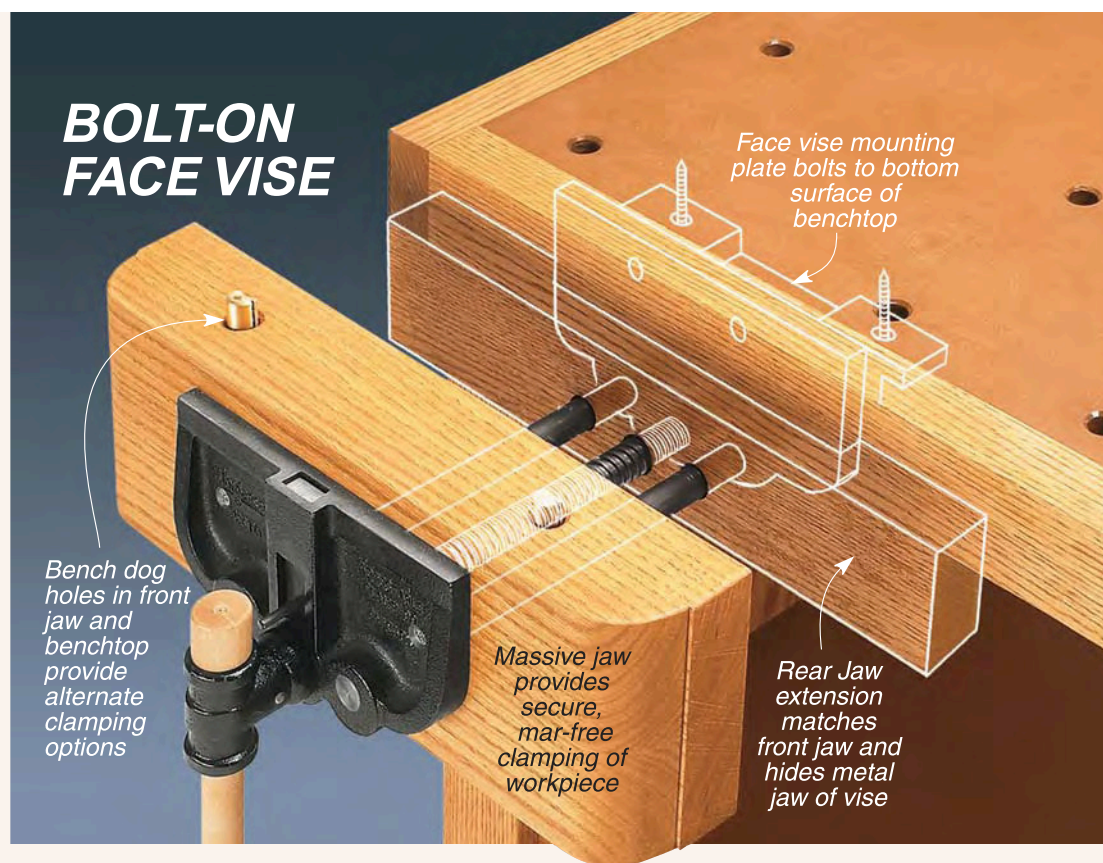

Prevent Racking

About the only problem you'll run across with a face vise is when you clamp a workpiece near one edge, as in the photo at right. As you start applying pressure, the vise begins to rack, or twist, to the other side. Besides being hard on the vise, the jaw won't clamp squarely against the work, so it isn't as secure.

To solve these problems, you can use a handy, "anti-racking" block on the opposite side. The block is just a thick piece of hardwood with a number of "steps" cut into it. To handle workpieces in a wide range of thickness, the steps are graduated in $\frac{1}{8}$ " increments.



SHOP TIP

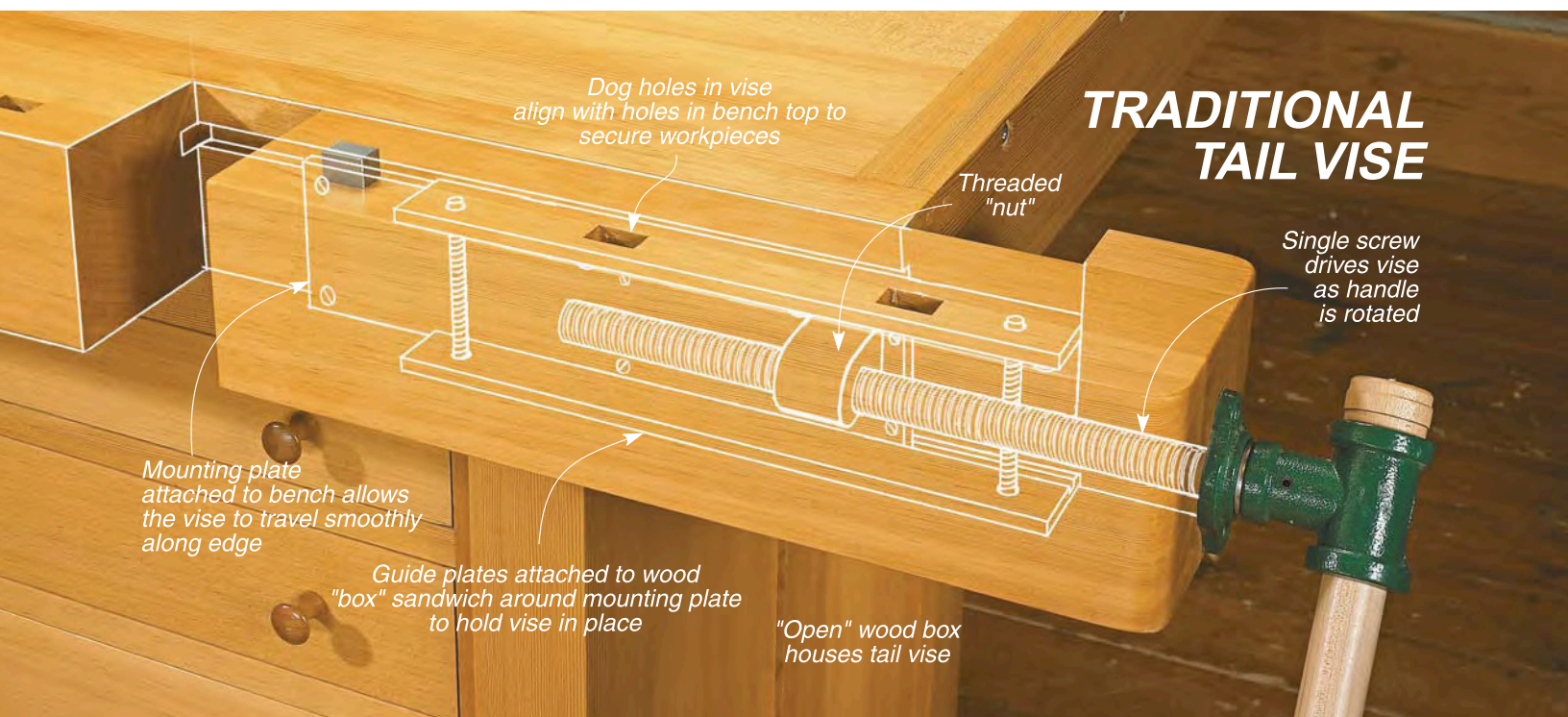

TRADITIONAL TAIL VISE

working with a Tail Vise

Although I use my face vise a lot, the vise I couldn't do without is the tail vise installed at the end of my workbench. Whether I need to secure a long workpiece for planing or hold a wide panel for a little belt sanding, my tail vise is up to the challenge.

TRADITIONAL TAIL VISE

A traditional tail vise, like the one you see above, securely clamps a workpiece to the *top* of your workbench, yet still allows you to work

without any interference. To do this, the vise has a few dog holes that align with a long row of dog holes in the front edge of the bench. With a pair of bench dogs, holding just about any workpiece is a snap.

Note: For more versatility, you can even clamp a workpiece between the face of the sliding jaw and the bench.

How a Tail Vise Works. Although a tail vise looks like a solid assembly, it's really a wood box with an open back. It's the hardware inside that's the secret to how a tail vise works. To see what I mean, take a look at the illustration above.

The hardware inside consists of a steel mounting plate attached to the front edge of the workbench. This fixed plate has a threaded "nut" that accepts the screw of the tail vise. As you turn the handle, the vise assembly slides back and forth along the mounting plate.

To keep the vise level and sliding smoothly, a pair of steel guide plates are sandwiched around the top and bottom edges of the mounting plate. You want to build the wood box so that when the plates are sandwiched around the mounting plate, the tail vise assembly is rock solid, yet will still move easily.

Planning for a Tail Vise.

The downside to a tail vise is that installing one requires the most planning. The reason for this is you have to design the top of the bench around the vise. So it's especially important to have the vise on hand before you start building your workbench.

And like a face vise, you'll have to decide on the capacity you'd like. In this case, the capacity is actually the back and forth travel of the vise. And building it into the workbench doesn't affect this movement. So the capacity specified is pretty much what

versatile clamping: Bench Dogs & Pups

So what do you do if you already have a workbench and can't add a tail vise? You can do the next best thing. And that's to use the handy hardware you see at right.

These *Veritas Wonder Pups* and round bench dogs from *Lee Valley* only require drilling a series of $\frac{3}{4}$ "-dia. holes in the top of your bench. Plus, by drilling a few more holes in your workbench and the jaw of your face vise, the vise can hold workpieces much larger than the capacity of the vise.

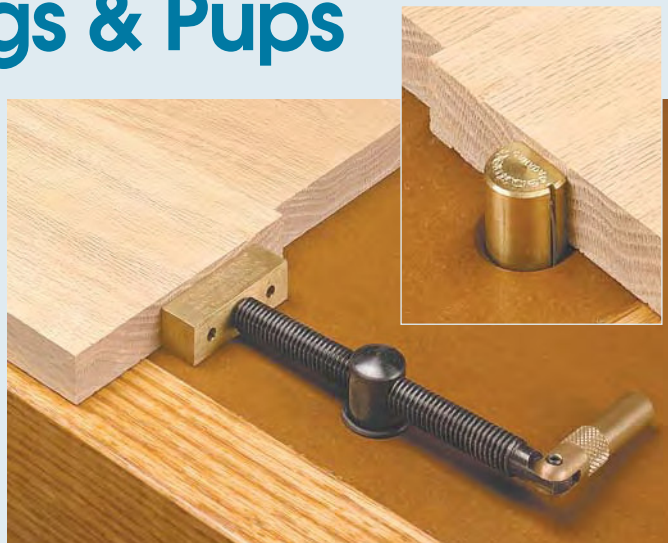

TWIN-SCREW VISE

you get. (For a way to incorporate the capability and features of a tail vise into an existing workbench, check out the box at the bottom of the opposite page.)

TWIN-SCREW VISE

One of the more unique vises you'll find on a workbench is the one you see in the photo and drawings at right and below. Instead of a single screw moving the jaw in and out, this vise uses two handles along with a pair of screws.

How it Works. Now this doesn't mean you have to turn both handles at the same time to secure a workpiece. Under the cover you see is a chain that connects the two screws (see lower right photo). Turning either handle causes both screws to turn together.

This way, the jaws stay parallel automatically and the vise won't rack no matter how much you pressure you apply to the workpiece. (A spring-loaded lock pin allows you to disengage the chain to skew the jaws for *slightly* tapered or out-of-square assemblies.)

Two Vises in One. What I really like about this vise is that you get two for the price of one.

By drilling holes in the top of the bench and the front jaw of the vise, it works like a tail vise. (You can clamp anything up to the length of your workbench, plus the nearly 12" capacity of the vise.)

Don't need a tail vise? Simple. Just clamp a workpiece anywhere between the jaws and use it like a

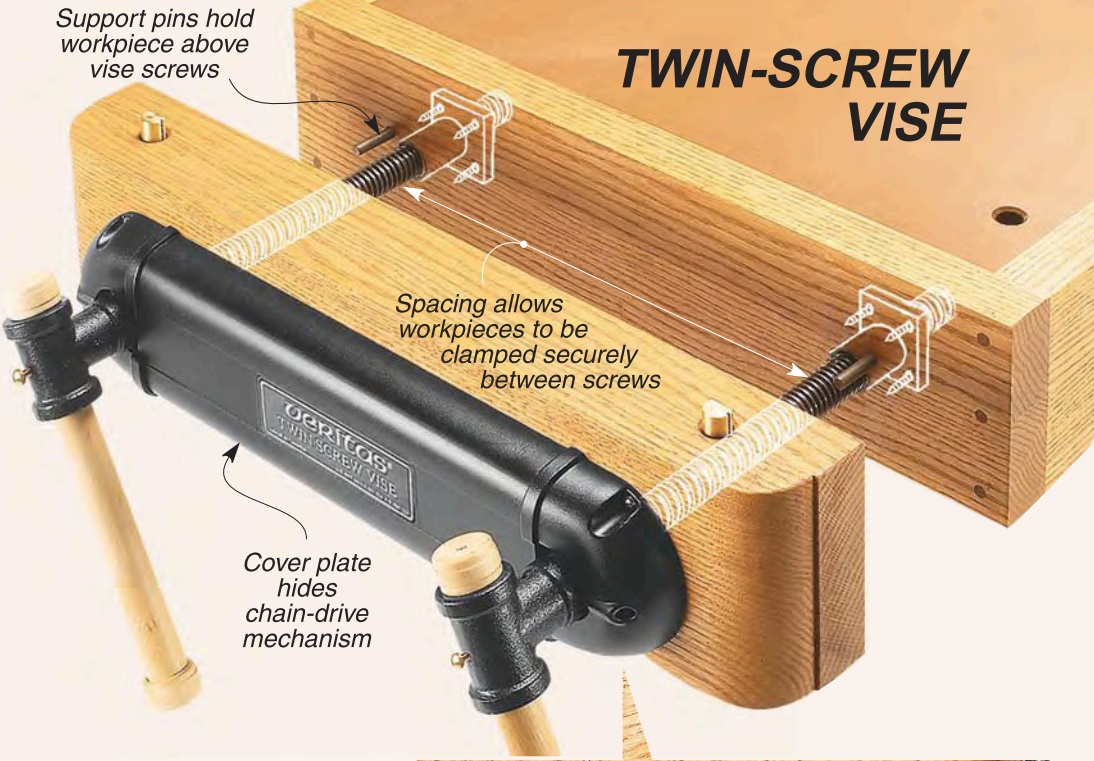

face vise. As an added plus, you can slip a wide workpiece vertically between the screws to work on it.

Note: You can easily install a twin-screw vise along the front edge of a workbench to make a great, large-capacity face vise.

It's All in the Kit. No matter where you install the vise, what you start with is a hardware kit made by Veritas that includes everything you'll need but a set of wood jaws (see page 51 for sources). The kit allows you to retrofit the vise to an existing bench or design it in from the start.

The kit comes in two "sizes" depending on how far apart you'd like to place the screws. One kit handles spacing the vise screws up to 16⁷/₈" apart, while the other kit



includes a longer chain so you can space them 24" apart.

The Choice is Yours. A face vise, a tail vise, or both — what you add or build into a workbench will provide you with more capability and improve your woodworking. 

CROSS SECTION

