

# Best-Ever Outfeed Table

Versatile workstation stores  
all your tablesaw gear  
and then some

BY JOHN WHITE



**Shelve  
your sled.**  
A dedicated shelf  
keeps the crosscut  
sled out of the way  
but easily accessible.



**No wasted space.**  
You can do glue-ups and  
other bench tasks on this  
table, so you'll need tools  
and supplies nearby.

**Blades at the ready.**  
The bottom drawers are  
deep enough to store  
blades vertically, making  
them easier to  
identify and pull out.



**Stow your  
fence.** A well-  
placed rack  
keeps the rip fence  
close at hand.

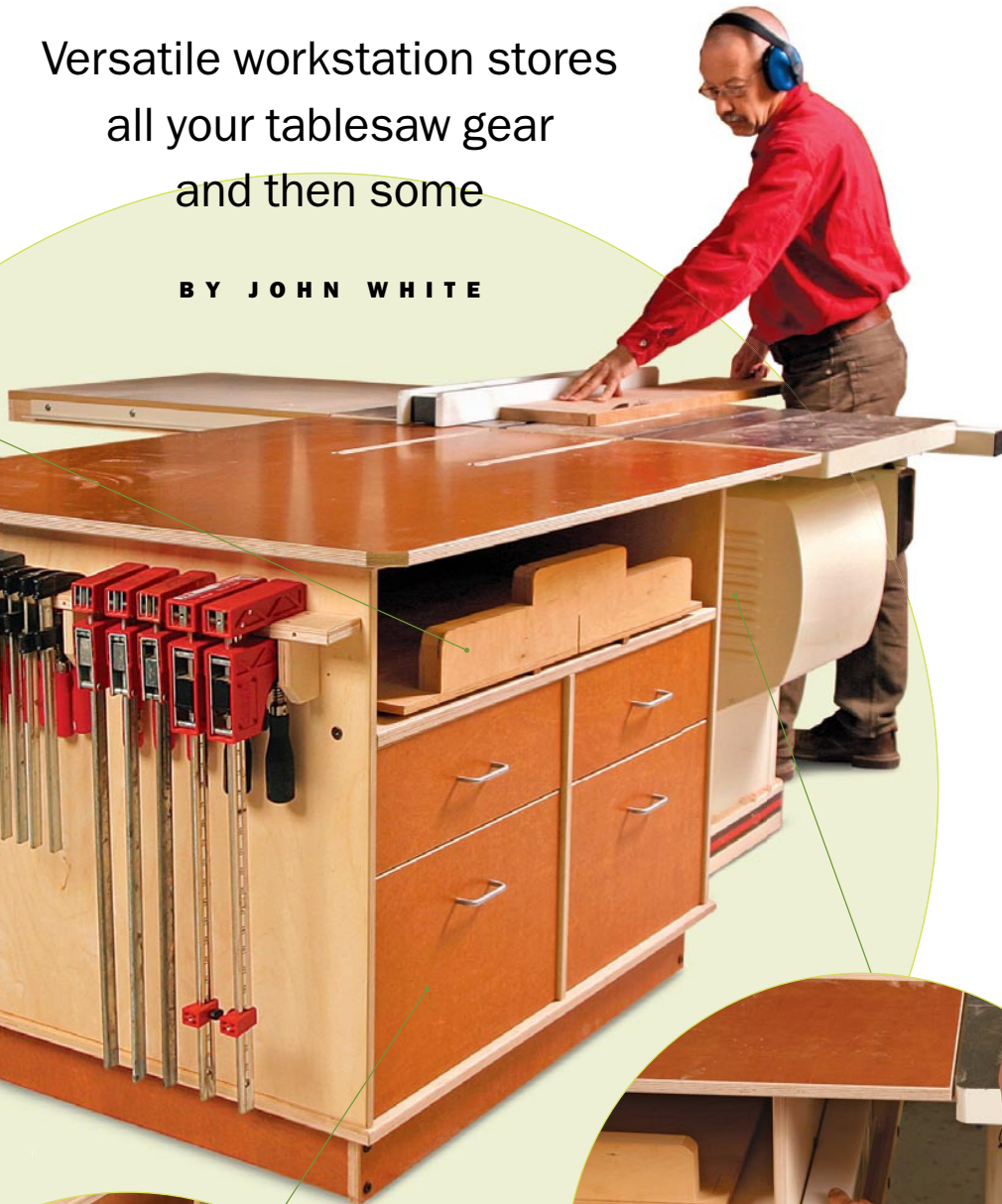

## PRECISE PLYWOOD PIECES

Use a circular saw and guide to square up factory-cut edges and to cut parts to a manageable size for the tablesaw.

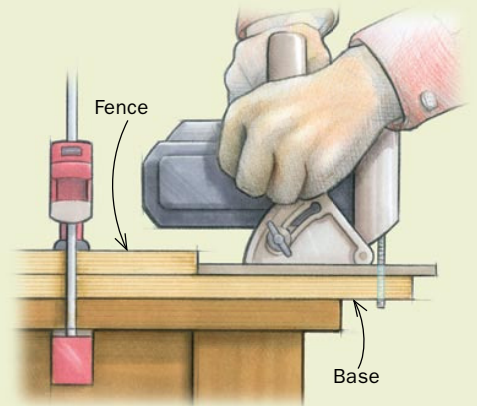

**Make a cutting guide.** Attach a fence to a slightly oversize base. Then trim the guide with a circular saw to establish a dead-accurate reference for lining up cuts.

**How to use it.** Align the guide so that the first cut not only gives you a straight side, but also a square corner.

A good outfeed table is essential for safe woodworking, because it allows you to control the workpiece as it moves past the blade and off the back of the tablesaw.

Without it, you'll have to push down hard on the back of long boards, which makes it difficult to guide them safely past the blade. An outfeed table also naturally doubles as a work surface for assembly and finishing. But the space beneath the table often lies unused, a wasted opportunity for efficient storage.

This outfeed table has a cabinet below that takes advantage of that space, with dedicated storage areas for the rip fence, miter gauge, crosscut sled, blades, and several big drawers for jigs. And there's plenty of shelf space for general storage, as well as room on the end panels for clamps. The large phenolic-plywood top is great because it's so slick that materials almost float across it. And because the surface resists stains and glue, it's perfect for assembly and finishing. I let the top overhang the base for easier clamping.

It's easy to adjust the table's height and level it, too. So if you move to a new shop, you won't need a new table.

Best of all, this outfeed table is not difficult to build. The hardest part may be dealing with the large sheets of plywood, but I'll offer tips that make breaking down and squaring the material easier. All of the joinery is simple. The cabinet itself is joined by butt joints held together by screws (I'll offer pointers on assembling the joints accurately). The drawers are joined by a rabbet-and-groove joint that requires only two tablesaw setups.

### Materials improve function and ease construction

This cabinet is built entirely of sheet goods, except for two Douglas-fir runners. The top, drawer fronts, and kick plates come from a single 4x8 sheet of phenolic plywood. The cabinet is  $\frac{3}{4}$ -in.-thick Baltic-birch plywood and the drawers are  $\frac{1}{2}$ -in.-thick Baltic-birch plywood.

The entire table can be made more economically from medium-density fiberboard (MDF) or ordinary plywood, but you'll have to use connecting bolts with barrel nuts to make strong joints in the softer MDF. With plywood, you can use screws. And you'll need to apply a finish to the

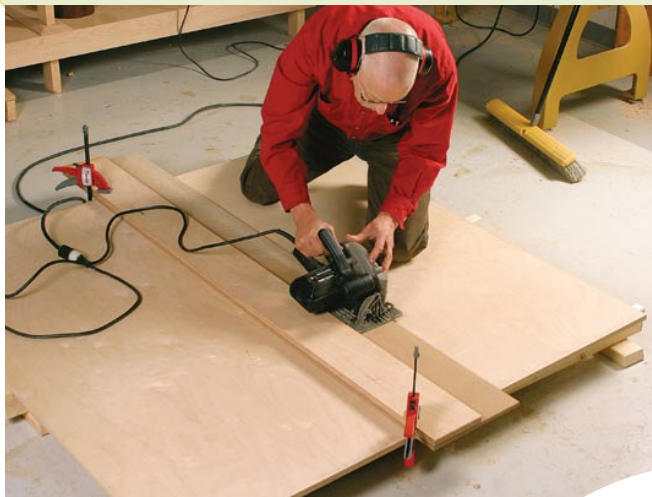

### TIP

**Bar-clamp handle.** When trimming the panel square, use a bar clamp to help hold it against the fence. A block at either end helps keep the clamp in position.

# BASIC ANATOMY

Baltic-birch and phenolic plywood combine for good looks, a sturdy base, and a low-friction top. Adjust the height shown here to fit your saw.

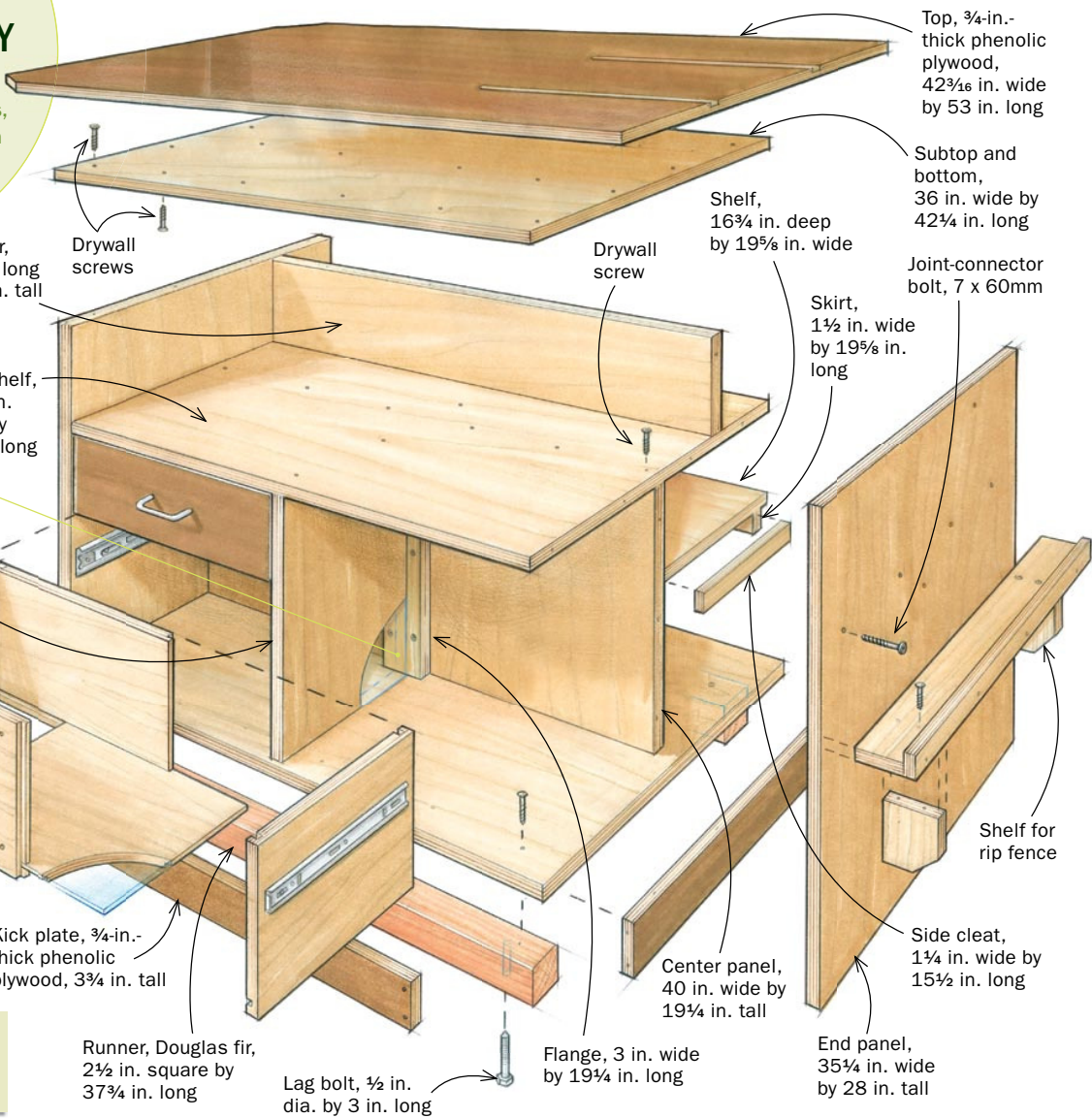
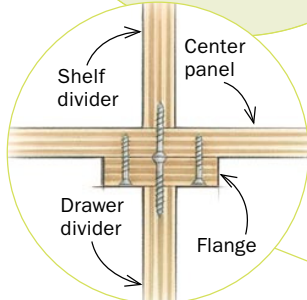

Full-size plans for this outfeed table (including plywood cutting diagrams) are available at [FineWoodworking.com/PlanStore](http://FineWoodworking.com/PlanStore).

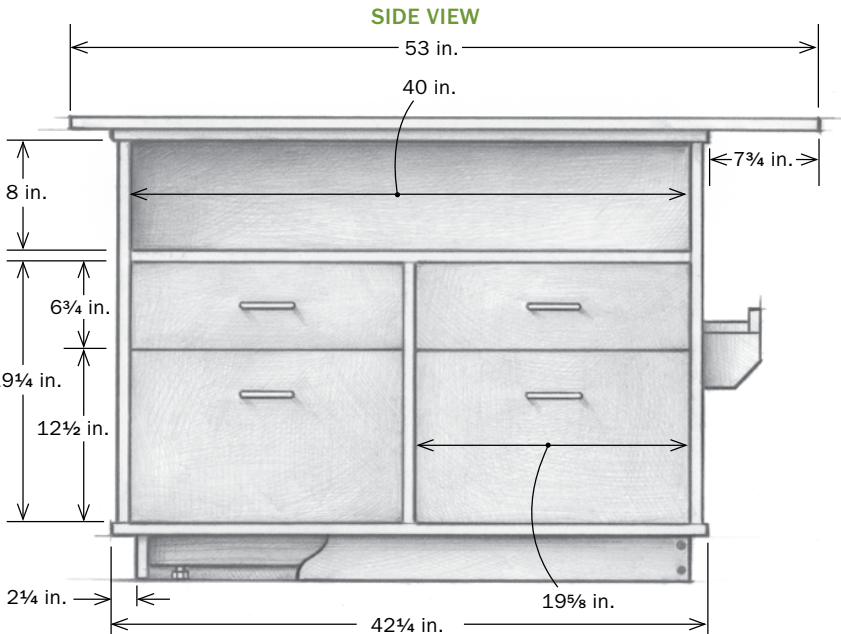
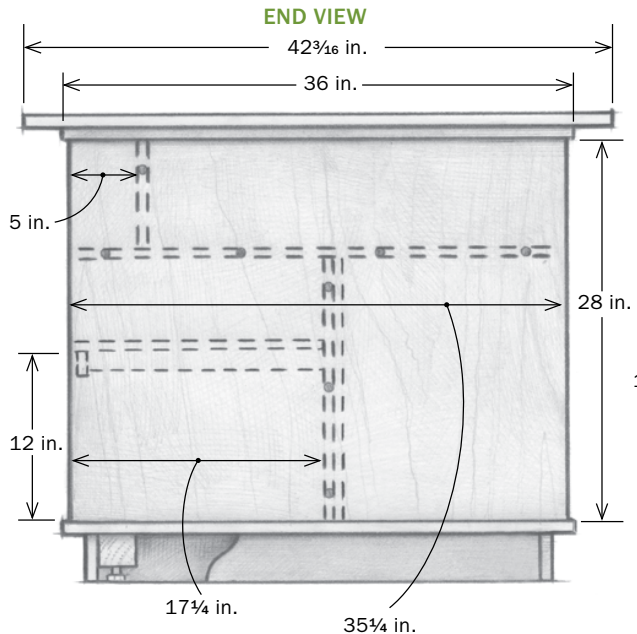

## JOINERY TIPS

Careful layout of joint locations and a few well-placed brads take the fuss and frustration out of butt joints. The layout lines show you where to drill, and the brads act as a third hand to hold the panels steady as you mark screw locations.

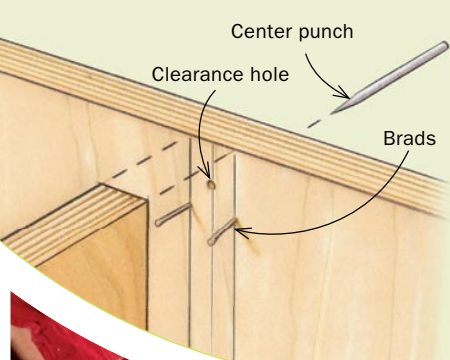

**Drill along the centerline.** Two lines show the edges of the intersecting panel. The third line marks the centerline for the clearance holes.



**Brads are helping hands.** Brads driven in along the edge lines will hold the intersecting panel in place as you transfer the location of the clearance holes. A pair at the top and at the bottom is all you need.



**Transfer the pilot-hole locations.** With the two panels aligned and held in place, slide a center punch through the outer panel and tap it to mark locations for the pilot holes. Disassemble the parts and drill the holes.

tabletop to toughen it and seal it against stains and glue.

### A guide for square panels

You can't rely on the factory-cut edges being square to each other, and full sheets are hard to handle on the tablesaw anyway. Solve both problems by using a circular saw and cutting guide to break down the sheet into smaller workpieces.

Set the guide so that it cuts an edge square to a factory edge. Use a sanding block to clean up the two square edges and then measure and mark the panel's final dimensions. Trim it to size on the tablesaw, running the square edges along the fence.

Bevel all edges on the panels with a chamfer bit. This prevents damage to the panels and adds a bit of safety. A square phenolic edge is very sharp and easily can cut you. Beveled edges also create crisp shadow lines at the joints, which I like.

### Screw joints are solid

All of the table's joints, except those in the drawers, are simple butt joints held together with screws. Where they wouldn't



**Use a drill to start the screws.** Drive in the joint-connector bolts, leaving them about  $\frac{1}{8}$  in. proud of the panel.

**Hand torque brings them home.** Use an Allen wrench to drive the bolts flush with the panel. A drill might over-drive the head or strip the pilot hole.

## LOGICAL ORDER FOR ASSEMBLY

Start with the center and end panels because everything else is built around them. The bottom keeps these parts square and stable while you attach the rest of the components.

**Start with the core.** Assemble the end panels and center panel, and trace their locations onto the bottom. Mark centerlines, drill holes for the drywall screws, and then attach the bottom.



**Add the dividers.** Attach the shelf divider first. Then install the flange (see drawing, p. 38) and drawer divider.



**The sled shelf is next.** Drive joint-connector bolts through the end panels into the sled shelf. Use drywall screws to secure the shelf to the drawer and shelf dividers.



**Flip the cabinet to attach the feet.** Lag bolts screwed into Douglas-fir runners make easily adjustable feet. After flipping over the cabinet, attach the runners with drywall screws.

be visible, I used drywall screws. Where the screw heads are exposed, I used joint-connector-bolt wood screws ([www.mcfelys.com](http://www.mcfelys.com), #1423-CWB), which have large, bronze-colored heads that look good on shop furniture. Although these are called bolts, they're actually hefty wood screws that need clearance and pilot holes drilled before you drive them home (see photos, p. 39).

Butt joints can be hard to align and assemble, so I use a couple of tricks to make things easier. First, I mark where one panel butts against the other. With these lines drawn, it's easy to tell where the joint is located and to drill accurate clearance or pilot holes along the centerline.

## TABLE TOPS IT OFF

Attach the phenolic top from below. That way, its smooth surface is unbroken except for the miter slots, which provide clearance for gauges and sleds.

Once the clearance holes are drilled, you need to transfer their centers onto the edge of the intersecting panel so that you can drill pilot holes. But it's not easy to hold everything in alignment when you do that, so I drive a few brads into the edge lines drawn earlier to trap the panel and hold it steady while I transfer the centers. I pull out the brads with a claw hammer when the joint is together. The layout lines and small nail holes left behind are hidden inside the case.

### Assemble the table in stages

I built my table in stages to avoid accumulated errors, but some parts should be cut in groups for uniformity. The cabinet's center panel can be cut at the same time as the drawer and shelf dividers because they need to be the same height.

Begin by assembling the end panels and the center panel. Once they're joined and square to one another, get the dimensions for the bottom and subtop by measuring the assembly and adding  $\frac{3}{4}$  in. to its width and length. The bottom and subtop overhang the core assembly by  $\frac{3}{8}$  in. on all four sides, which makes it easier to fit them because the alignment of the edges won't need to be exact. Attach the bottom, but not the subtop.

The drawer and shelf dividers are next. The shelf divider is simply screwed to the center panel. The back of the drawer divider, however, has a strip of plywood attached to it. Screws are then driven through the resulting flange to attach the drawer divider to the center panel (see detail, p. 38). This is necessary, because once the shelf divider is installed, you won't be able to drill through the center panel to attach the drawer divider.

After the dividers are in place, install the large shelf that provides storage for the sled. When you screw it down, keep the drawer and shelf dividers square to the center panel. Next, add the divider that serves as a back to the shelf.

You're now ready to attach the subtop, which adds stiffness to the phenolic top and makes it easier to screw it on. Before you attach it, drill and countersink a series of holes for the screws that will attach the phenolic top to the base. Drill them 6 in. apart around the subtop's perimeter and about 2 in. from the edge. Do the same around the center. Now, attach the small shelf on the side of the table. To keep things simple, I screwed the shelf to a pair of cleats, which are hidden by a skirt on the front edge.

Flip over the base and attach the two runners that receive the table's lag-bolt feet. These runners are made from



**Screws shouldn't show.** After the table has been righted and the subtop attached, you can put the phenolic top in place. Secure it from below with dry-wall screws.



**Make way for the miter gauge.** Put the outfeed table in place—leveled and adjusted to the right height—and use the saw's miter gauge to locate the clearance slots.



### ROUT THE CLEARANCE SLOTS

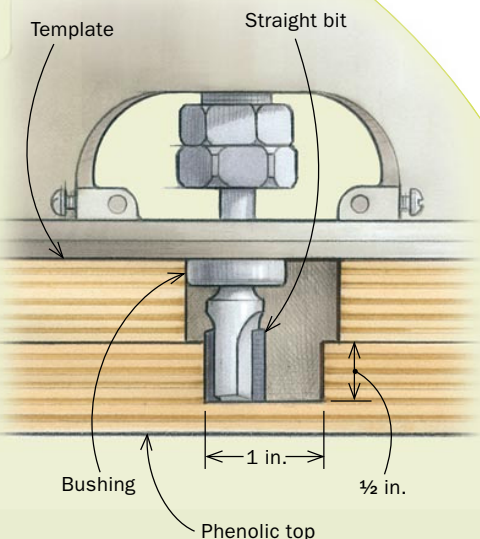

#### Jig makes quick work of wide slots.

White used a router equipped with a guide bushing and straight bit to cut the clearance slots. His method produces a wide, accurate slot without having to move a straightedge for multiple passes.

# SIMPLE JOINERY, STURDY DRAWERS

Build the whole drawer box with just two tablesaw setups, one for the grooves and one for the rabbets.

First setup cuts dados for the front and back, and grooves for the bottom panel.

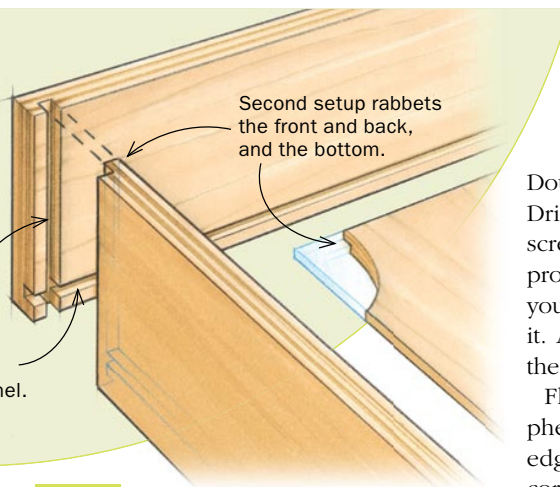

Second setup rabbets the front and back, and the bottom.

## 1 Dados and grooves

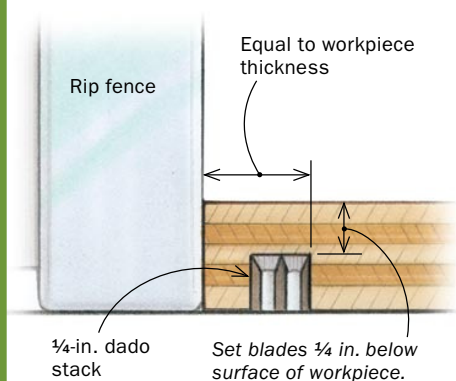

## 2 Rabbets

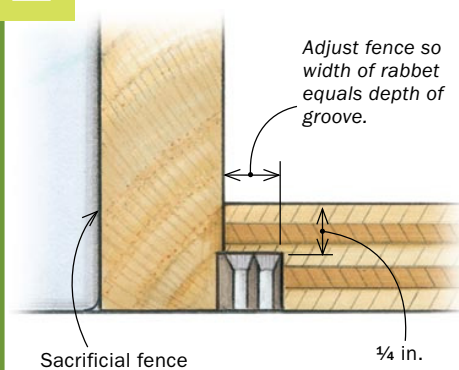

**Dados in the sides.** Use a miter gauge to guide the drawer sides safely along the rip fence.



**Rabbit the fronts and backs.** With the dado head buried in a sacrificial fence, cut the rabbets for the corner joints.



**Grooves for the bottoms.** Run the bottom of the sides, fronts, and backs against the fence to cut the groove for the bottom panel.



**Rabbit the bottom panels.** All four sides of the bottom panels are rabbeted to fit into the grooves running around the bottom of the drawer box.

Douglas-fir 4x4s trimmed to 2½ in. square. Drill pilot holes for the lag-bolt feet and screw them in, leaving them about 1 in. proud of the runners. The lag bolts allow you to adjust the table's height and to level it. Attach them 2¼ in. from the edge of the bottom.

Flip the base back over and attach the phenolic top. In addition to beveling the edges of the panel, I trimmed the two corners opposite the saw at 45°, which is easier to do with the top attached.

Next, level the cabinet and bring the top in line with the saw's table. Then transfer the location of the miter slots directly from the saw table and mark them out on the top. Mine are ½ in. deep by 1 in. wide by 20⅞ in. long. To cut the channels, you only need a router, a straight bit, and a straightedge, but I made a template and used an offset guide bushing, which allowed me to rout the entire channel without having to adjust a straightedge to get the full width.

For dust clearance, I drilled a ¾-in.-dia. hole about 6 in. from the end of each channel. The dust falls into the gap



**Assembly is easy.** Go easy on the glue to avoid squeeze-out. Use brads to hold things snug as the glue dries.

## ADJUST THE HEIGHT

The lag-bolt feet let you adjust the table to be level and just the right height.

between the back of the saw and the outfeed table.

### A fast drawer joint that lasts

You can build the drawer boxes in a variety of ways, but I recommend a rabbet-and-groove joint that requires only two setups on the tablesaw. These drawers are quite strong and can be made in short order.

The drawer boxes are made from Baltic-birch plywood that's just a hair under 1/2 in. thick, but that doesn't mean the joint is harder to cut. You'll cut all of the dados and grooves with the first setup, and all of the rabbets with the second (see photos, facing page). The dados, grooves and rabbets are cut with a 1/4-in. dado stack set at the same height, so you'll only need to reset the fence between setups.

The easiest way to assemble the drawers is to brush a small amount of glue on the rabbets (you want to avoid squeeze-out) and tack the joints together with two or three small brads. The brads will hold the joint snug as the glue dries. Clamping is time-consuming, and the weight and pressure of the clamps can throw the drawer out of square.

I used standard ball-bearing, full-extension slides from a home center to mount the drawers in the outfeed table.

### Attach the drawer fronts and kick plate

Fit the fronts with the table in place and adjusted for height and level. The table might twist a bit as a result of the adjustments, and you'll get a better fit after them.

The four pieces of the kick plate are screwed to one another at the corners, but aren't attached to the cabinet. This makes them easy to remove should you need to tweak the table's height if you move the saw and table.

A few coats of shellac on the Baltic-birch plywood will give it some protection.

Your newly minted outfeed table will make your shop safer and better organized. And that will make your woodworking more enjoyable. □

*A former shop manager at Fine Woodworking, John White is now a freelance writer living in Vermont.*

[www.finewoodworking.com](http://www.finewoodworking.com)



**Check for a consistent gap.** The outfeed table should be a hair below the saw table. Hold a straightedge firmly down on the tablesaw to check.



**Quick adjustments.** The coarse thread of the lag bolts makes for speedy height adjustments.

## CAP IT OFF

Phenolic drawer fronts and kick plates are durable, but also give the cabinet a unified look and subtle pop.



**Add a kick plate.** The plate hides the feet and stops things from rolling under the cabinet. It's easy to remove to make height adjustments.



**Install the false fronts.** Use shims and double-faced tape to position each drawer front, and then screw it on from the inside.